

14 SERIES LINEAR SERVO AMPLIFIERS

PVP143

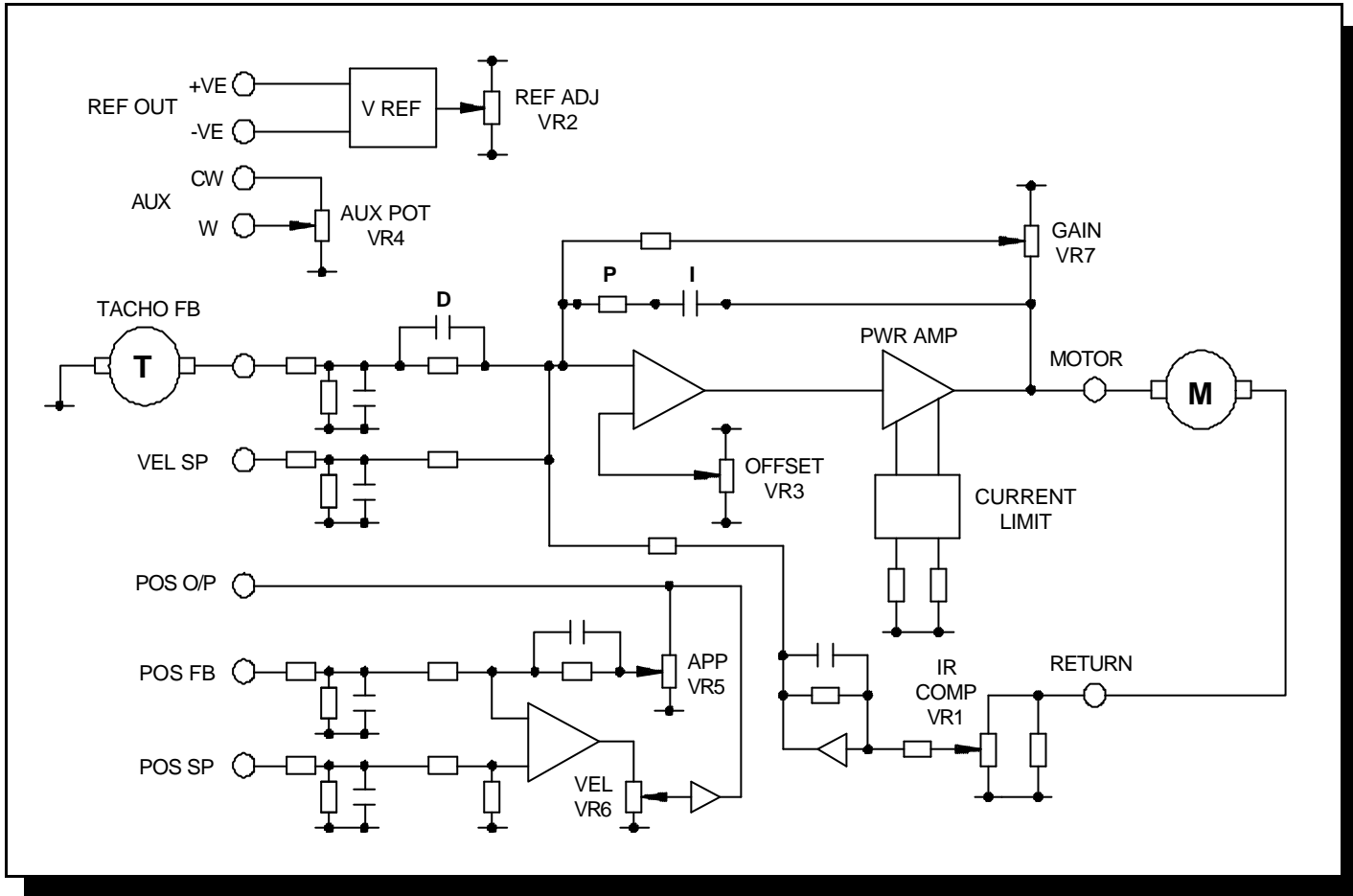

The PVP143 Linear Servo Amplifier has been developed to meet the growing demand for high performance, low cost drives. It has been designed to match the specifications of most DC brushed permanent magnet servo motors with a voltage range of 6 to 28 volts.

Features include: Low EMI / RFI emission; 4 Quadrant operation; Pre-setable current limit circuit with automatic current boost facility in both directions; An adjustable voltage reference for use with external setpoint potentiometers; Velocity and position modes with adjustable positioning velocity and approach rate in position mode; Tachogenerator or IR (armature) feedback capability in both velocity and position mode.

The PVP143 is available as an OEM module or can be supplied with Alzanti's range of power supplies and intelligent motion controllers built in a Eurorack format.



Mclennan Servo Supplies

Unit 1, The Royston Centre, Lynchford Lane,
Ash Vale, Surrey. UK GU12 5PQ
Tel: +44 (0) 8707 700 700
Fax: +44 (0) 8707 700 699
Email: sales@mclennan.co.uk
Website: <http://www.alzanti.com>

TECHNICAL DATA

Supply Rail Voltage (Vs):	± 12 to 30Vdc smoothed, unregulated (+10% max)
Output Voltage:	Better than Vs - 3V at full load
Output Current:	2 Amps continuous up to 30 Watts max.
Output Current Adjustment:	Set via on-board resistors
Current Boost:	Typically 2:1 for 1 second, from set value, depending on load. Maximum duty cycle 20% at continuous rating without assisted cooling.
Signal Input Impedance:	Nominally 100K Ω depending on configuration
Reference Voltage Output:	Factory set at ± 5 V, adjustable from ± 4 V to ± 6 V
Reference Voltage Current:	± 10 mA maximum
Operating Temperature Range:	0 to 40°C
Connector:	32 way row a & c to DIN41612 style D
Printed Circuit Board:	1.6mm glass fibre with solder mask and component ident
Weight:	500 grams

